



MSZ Ceramic Tube Single Bore

High-Toughness Ceramic Tube Solutions for Thermal Shock, Corrosion, and High-Temperature Duty

Contact Information

 Tel: +86-0731-84428843

 Whatsapp: +86-19311583352

 E-mail: info@adcerax.com

 Website: <https://adcerax.com>

 Address: Building 108, Industrial Park, Liling city Hunan Province, China



About ADCERAX

Powered by **HUNAN ATCERA CO.,LTD** – A Trusted Innovator in Advanced Ceramics Since 2010 ,**HUNAN ATCERA CO. Ltd** has been deeply engaged in the field of advanced ceramics for 20 years, and has production experience of more than 2000 precision ceramic products. We focus on the material of alumina ceramics, zirconia ceramics, silicon carbide ceramics, silicon nitride ceramics, aluminum nitride ceramics and quartz, etc., and aim to provide you with advanced ceramics one-stop service.

Adcerax delivering bespoke advanced ceramic solutions for industries where precision and durability matter. And has become a leading global China supplier of zirconia ceramic tubes, with products exported to the United States, Germany, Japan, South Korea, and many other countries.

Our Expertise



Engineering Support: Professional product engineers providing timely technical assistance from design to production.



Customization Capability: Accepting small-batch custom orders based on customer drawings or samples.



Rapid Delivery: Quick shipping for custom orders and 24-hour dispatch for in-stock standard products.







Supply Chain Integration: One-stop customization and procurement services leveraging China's supply chain advantages.



ADCERAX Promise

Your ROI Starts from Day One

-  37% Lifespan: Industry Standards Verified by SGS Third-Party Testing in Extreme Thermal Shock Environments
-  22% Downtime: Reduce unplanned downtime with ceramic component life enhancement
-  15 days fast response: From drawing confirmation to functional prototype delivery
-  12 months warranty: Unconditional return of quality problems to factory for remanufacturing + process optimization report



Our Certifications



What is MSZ Ceramic Tube Single Bore?

MSZ Ceramic Tube Single Bore is a magnesia-stabilized zirconia ceramic tube with one straight internal hole. It is a high-performance zirconia tube designed for applications that need high strength, good fracture toughness, corrosion resistance, and strong thermal shock resistance under demanding industrial conditions.

Typical uses:

- ◆ Furnace protection systems
- ◆ High-temperature process equipment
- ◆ Wear-resistant sleeves and liners
- ◆ Chemical handling systems
- ◆ Industrial insulation components



MSZ Ceramic Tube Single Bore Process



Raw Material Preparation

Alumina powder is selected and mixed with binders and plasticizers to form a uniform slurry or paste.



Forming

Extrusion: Alumina slurry is extruded through a die into continuous tubular shapes.

Isostatic Pressing: Powder is molded under high pressure to form high-density, uniform tubes.

Slip Casting: Liquid slurry is cast into a mold and solidified.



Drying

The formed tubes are dried slowly to remove moisture and prevent cracking or deformation.



Sintering

The dried tubes are fired in a high-temperature kiln (typically 1600–1700°C) to achieve full densification and develop the final ceramic properties.



Machining

After sintering, the tubes may be ground or machined to achieve precise dimensions, surface finish, or special features such as chamfered ends or holes.

MSZ Ceramic Tube Single Bore Properties

Property	Specification
Density	~5.7 g/cm ³
Flexural Strength	>800 MPa
Fracture Toughness	8–10 MPa·m ^{1/2}
Thermal Expansion Coefficient	Thermal Expansion Coefficient
Maximum Operating Temperature	>1000 °C continuous
Hardness (Vickers HV1)	~12 GPa
Corrosion Resistance	<2% weight loss, 48h H ₂ SO ₄ exposure

Why Choose a Magnesia Stabilized Zirconia Ceramic Tube?

- Better crack resistance during installation, handling, and thermal cycling
- More reliable performance in foundry, reactor, and high-temperature process equipment
- Longer service life in duties where alumina tubes may become too brittle
- Lower contamination risk and less unplanned downtime in corrosive operating conditions

MSZ vs alumina in demanding cycles

ADCERAX states MSZ can extend component life by up to 2–3× compared with alumina when thermal shock and fracture toughness are the dominant failure modes.

Best suited when you need:

- frequent thermal cycling
- high resistance to cracking
- stronger survival during immersion and handling

Best to verify before purchase:

- exact process temperature window
- media chemistry and wetting behavior
- mounting stress and tolerances

Technical Advantages

Engineered for high-temperature single-bore applications where toughness, thermal shock resistance, and structural stability matter more than low initial cost.



Transformation Toughening

Magnesia stabilization gives zirconia a tougher working structure, helping the tube resist crack growth under thermal and mechanical stress.



Higher Thermal Shock Tolerance

A better choice for repeated heating and cooling conditions where brittle ceramic tubes are more likely to fail.



Single-Bore Functional Design

Provides one precise internal passage for probe protection, alignment, gas transfer, or process separation.



Better Mechanical Reliability

Suitable for applications involving insertion force, vibration, fixture load, or local pressure concentration.



Harsh Process Suitability

Works well in demanding thermal process environments where structural stability and reliability are critical.



Reduced Replacement Frequency

Helps lower downtime risk in applications where unexpected tube fracture affects process continuity.

Magnesia Stabilized Zirconia Ceramic Tube Single Bore

MSZ Single-Bore Tube for Insulation, Protection, and High-Temperature Use

SPECIFICATIONS

Material	Magnesia Stabilized Zirconia
Type	Single Bore Tube
Function	Single-channel insulation and protection
Density	5.7–6.0 g/cm³
Customization	Custom size and wall thickness

APPLICATIONS

Thermocouple Assemblies · Lead Wire Protection · Furnace Insulation · Sensor Components · High-Temperature Equipment



KEY FEATURES

- 1 Single-bore structure for clean and reliable channel separation
- 2 Good thermal stability for demanding process conditions
- 3 Helps protect wires and components in heated systems
- 4 Custom sizes available for different assembly needs

MSZ Ceramic Tube Single Bore size:

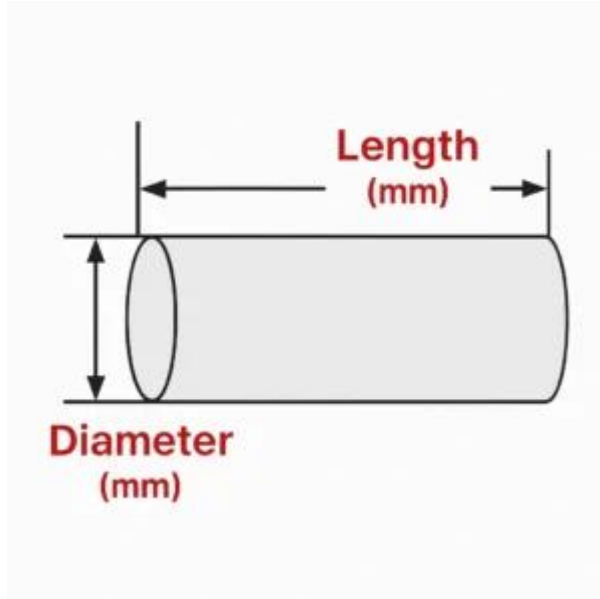

Model	Outer Diameter (mm)	Inner Diameter (mm)	Length(mm)
AT-MGO-G1001	3	1	20
AT-MGO-G1002	10	5	20
AT-MGO-G1003	15	7	25
AT-MGO-G1004	30	20	45
AT-MGO-G1005	40	32	50
AT-MGO-G1006	62.5	52.5	87

MSZ Ceramic Tube Single Bore Applications

Metallurgical thermocouple protection

- For molten-bath measurement, the tube is positioned as a higher-toughness alternative when cracking, immersion shock, and repeated air-quench cycles shorten the life of alumina sleeves.

Chemical process equipment protection

- Suitable for sleeves, liners, and hot-zone parts where acids, alkalis, oxidizers, and stop-start temperature shifts can erode or crack conventional ceramics.

Energy conversion systems

- Used where redox cycling, thermal ramping, and mismatch stress place higher demands on toughness and service stability.

How buyers can map application fit

1. Define the dominant failure mode.

Thermal shock, crack propagation, wear, chemical attack, or assembly stress?

2. Quantify the process window.

Continuous temperature, peak temperature, media chemistry, thermal ramp, and cycle count.

3. Check geometry-driven risk.

Wall thickness, unsupported length, bore requirement, end condition, and mounting constraints.

4. Compare total cost of ownership.

Include downtime, scrap risk, temperature drift, maintenance labor, and replacement frequency.

Application takeaway: MSZ single bore tubes are a strong choice when failure carries high cost and service conditions are demanding.

Customization Services for MSZ Ceramic Tube Single Bore

When standard sizes do not fit the system, ADCERAX provides application-based customization to optimize dimensions, wall structure, and end finishing for the actual installation.

Customizable Parameters

Geometry Options

- Outer shape — Customized form supports equipment design compatibility
- Inner bore — Configured dimensions match sensor or probe requirements
- Wall profile — Optimized structure balances strength and thermal stability

Surface Treatment Choices

- Smooth polish — Reduces friction and wear in mechanical assemblies
- Protective layer — Enhances corrosion resistance in chemical environments
- Functional texture — Improves bonding or alignment with surrounding parts

Engineering Support

- Drawing review — Assists in refining details for practical manufacturability
- Material advice — Guidance on Mg-PSZ stability in target conditions
- Performance check — Validates design against heat and corrosion demands



Customization Process



Fast Response Commitment

From drawing confirmation to functional prototype delivery

15 Days

MSZ Ceramic Tube Single Bore Usage Guide

--- Storage and Handling

- ✓ Store in a clean, dry environment to prevent moisture absorption.
- ✓ Handle with padded gloves to avoid surface scratches or micro-cracks.
- ✓ Keep tubes separated with soft packing to avoid edge impact.

--- Installation Practices

- ✓ Ensure fittings and housings are aligned to reduce stress points.
- ✓ Preheat gradually when introducing tubes to furnace environments.
- ✓ Avoid sudden temperature exposure during installation stages.

--- Operating Recommendations

- ✓ Limit rapid immersion into liquids after high-temperature use.
- ✓ Monitor operating cycles to avoid exceeding ΔT 600°C thresholds.
- ✓ Replace immediately if performance degradation is detected.

--- Maintenance and Service

- ✓ Clean with non-abrasive methods to preserve smooth surfaces.
- ✓ Avoid exposure to hydrofluoric acid or highly reactive fluoride salts.
- ✓ Request engineering consultation for custom maintenance strategies.



Technical Support

✉ Technical Inquiry: info@adcerax.com

📞 Service Hotline: +86-0731-84428843

💬 Whatsapp: +86-19311583352

MSZ Ceramic Tube Single Bore FAQ

✓ **Q: What makes MSZ Tube single bore suitable for thermal shock environments?**

A: It withstands rapid temperature change and helps reduce cracking during frequent heating and cooling cycles.

✓ **Q: How does Magnesia Stabilized Zirconia Tube improve thermocouple protection in foundries?**

A: It offers high toughness and strength at elevated temperatures, helping extend probe life and reduce replacement frequency.

✓ **Q: Why is Magnesia Stabilized Zirconia Tube used in chemical process plants?**

A: It resists chemical attack while maintaining strength at high temperature, helping protect process purity and service life.

✓ **Q: Can Magnesia Stabilized Zirconia Tube withstand mechanical stress during industrial use?**

A: Yes. Its high strength and toughness help resist bending, impact, and fracture in demanding operating conditions.

✓ **Q: Why does Magnesia Stabilized Zirconia Tube outperform alumina in high-temperature operations?**

A: It generally offers better toughness and thermal shock resistance, helping reduce breakage and unplanned downtime.



Service Support

ADCERAX is committed to providing comprehensive service support to customers, from product selection to after-sales maintenance.

Pre-Sales Support

- ✓ Expert technical team provides custom design advice
- ✓ Sample testing and performance verification
- ✓ Technical parameter consultation

Sales Support

- ✓ Order tracking and production progress updates
- ✓ Professional packaging and logistics solutions

After-Sales Service

- ✓ Product quality assurance and problem resolution
- ✓ Technical consultation and application support
- ✓ 24-hour response commitment

Quality Assurance

- ✓ Strict quality control system
- ✓ Product performance testing and verification



Contact Our Specialist Team

✉ Customer Service: info@adcerax.com

📞 Service Hotline: +86-0731-84428843

🌐 Online Support: adcerax.com/support

Contact Us

ADCERAX looks forward to cooperating with you and providing high-quality zirconia tube solutions. Our team is dedicated to serving you with any questions or needs you may have.

Contact Information

- +86-0731-84428843
- info@adcerax.com
- +86-19311583352
- adcerax.com
- Building 108, Industrial Park, Liling city Hunan Province, China

Inquiry Process

1

Submit Inquiry

Submit your requirements via email, phone, or website form.

2

Technical Evaluation

Our expert team evaluates your needs and provides solutions.

3

Quotation Confirmation

Provide detailed quotation and delivery time based on your requirements.

4

Order Confirmation

Confirm order and arrange production and delivery.



Get in touch with us

We promise to respond to your inquiry within 24 hours.

Ready to enhance your product performance with zirconia tube? Contact our team for personalized consultation, technical support, and competitive quotations.

[Get A Quote](#)